

主軸頭 >>>

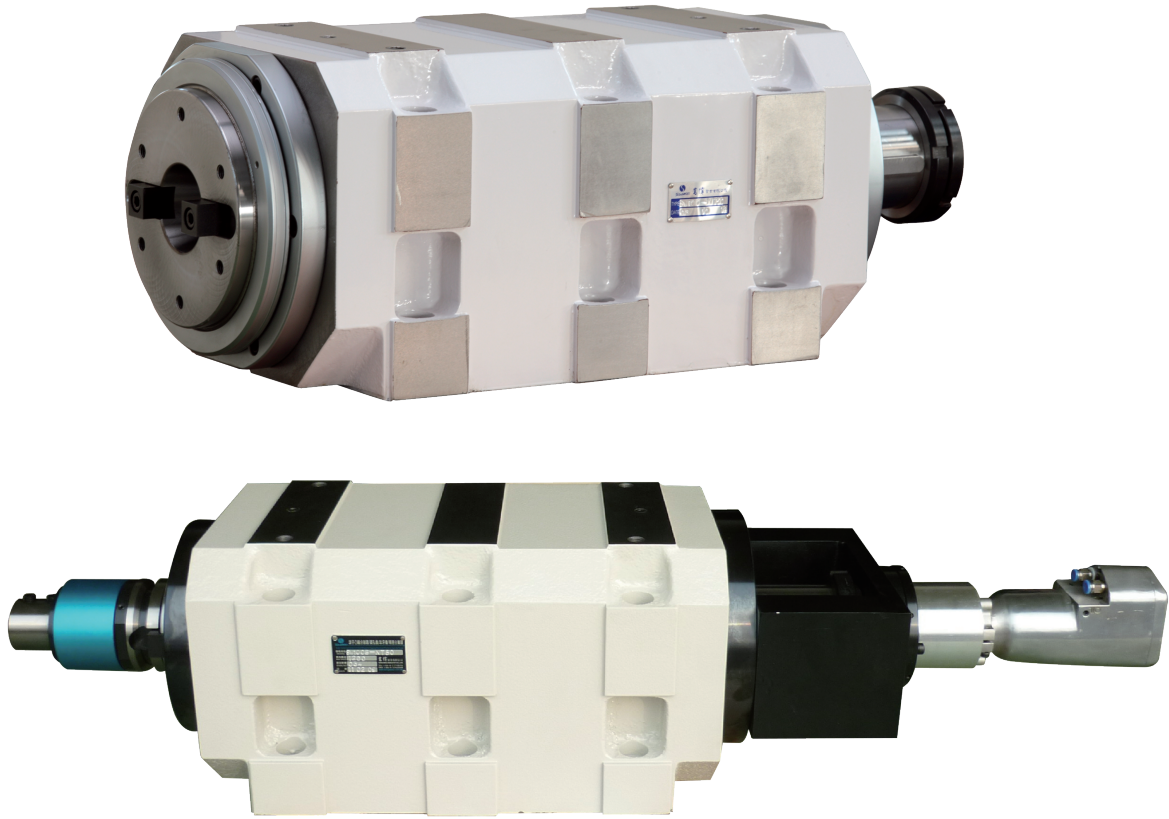

SW-100/SW-200

搪銑主軸頭 Boring & Milling Spindles Units

規格 Norms	Model	SW-100	SW-100H	SW-120	SW-120H
主軸軸承	Spindle Bearing	32220-2 / 6220Z-2	7220-4	332224-2 / 6224Z-2	7224-4
容許轉速	Spindle Max. Speed	800RPM	2000RPM	600RPM	1800RPM
上升溫度	Temperature Rise	20°C	20°C	20°C	20°C
容許馬力	Maximum use of motor	7.5KW(10HP)		7.5KW(10HP)	
主軸真圓度	Spindle Roundness	主軸與刀具配合面 MAX: 0.005mm		主軸與刀具配合面 MAX: 0.005mm	
潤滑方式	Lubrication method	Grease 潤滑油脂		Grease 潤滑油脂	
淨重	Net Weight	250kg		280kg	

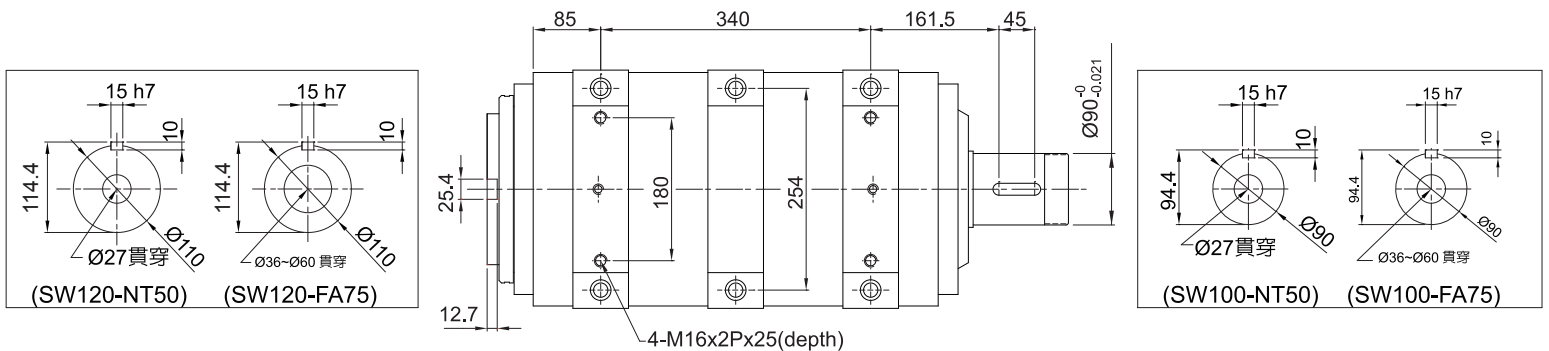

SW-100-FA75

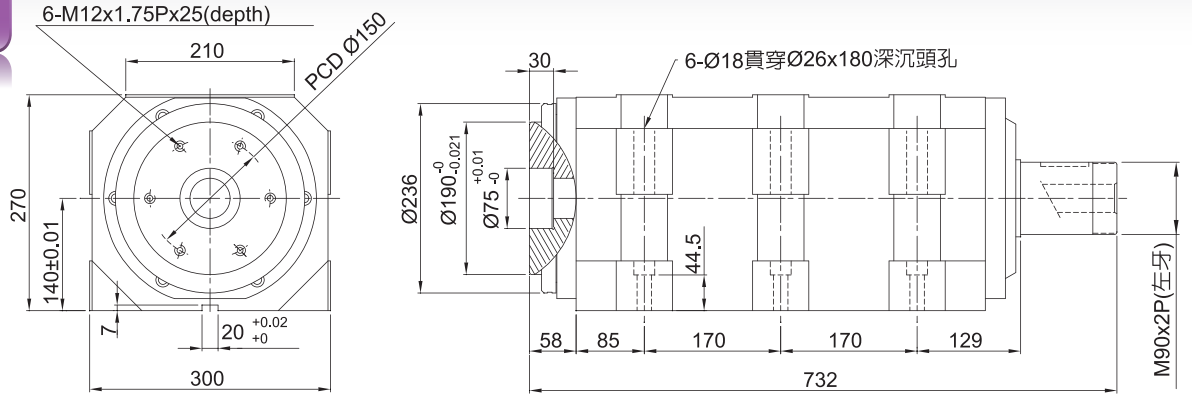

SW-100-NT50

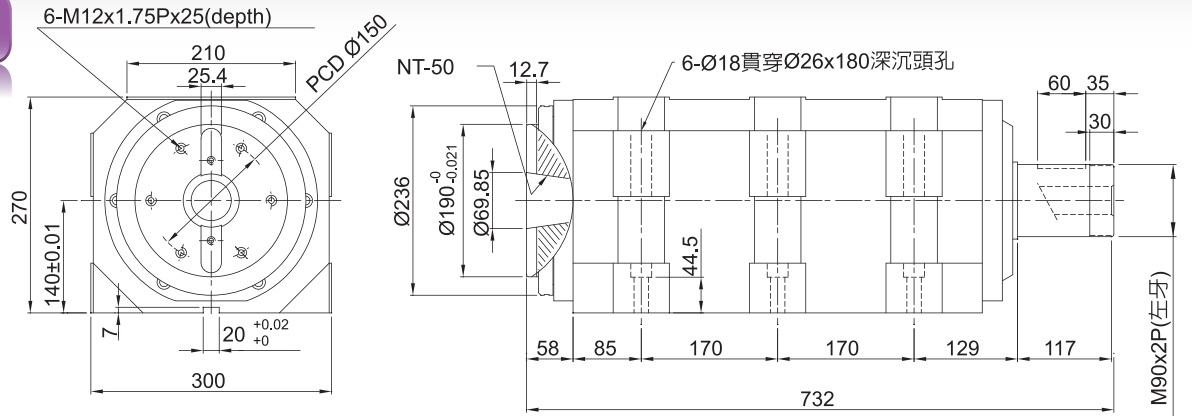

SW120-FA75

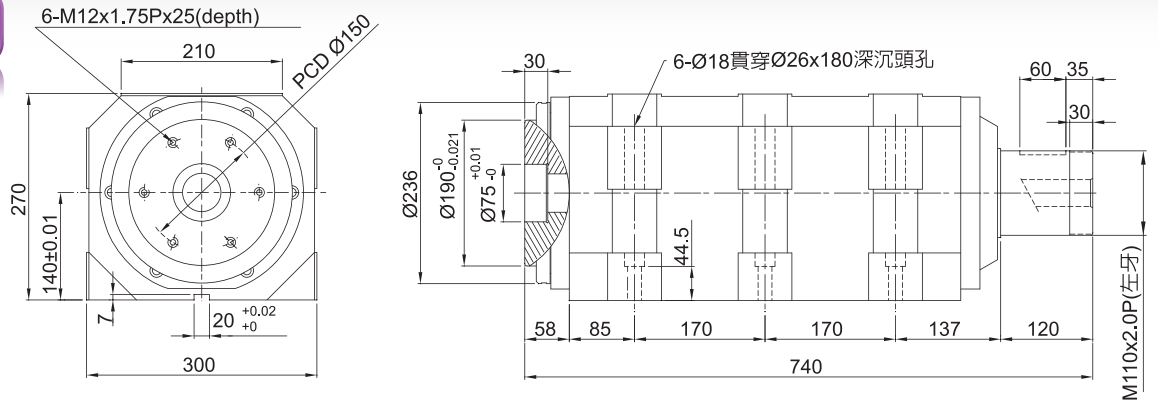

SW120-NT50

